

Kriegers Flak Offshore Wind Farm

Design Basis Foundations

Basic data for conceptual design of foundations

Status Concept

Version B1

2008-01-29

Lars Bülow Jørgensen Ljjj and
Helge Gravesen, HIG, (VN-PT)

PYP

Company Vattenfall Vindkraft AB	Org PYP	Document Report	Doc no in Captia	Version B1
Project Kriegers Flak Offshore Wind Farm	Author Lars Bülow Jørgensen Ljjj and Helge Gravesen, HIG, (VN-PT)		Status Concept	
Title Design Basis Foundations	Date 2008-01-29		Reviewed by Kim Ganshorn (VN-PT)	
Distribution			Approved by Göran Loman (VN-PY)	

Revision log

Version	Date	Ref	Purpose	Change since prev version
C1	2008-01-29	Ljjj, HIG		
B1	2008-01-13	GRLO		Rev figure 2.2

Contents

1 Revisions 1

2 Introduction 2

3 Design principles 5

4 Co-ordinate system..... 6

5 Wind Turbine 7

6 Foundation dimensions and tower interface..... 8

7 Combined Loads 10

8 Other design criteria 16

9 Secondary constructions..... 18

10 Geotechnical Design..... 21

11 Monopile: Geotechnical Parameters..... 28

12 GBS: Geotechnical Parameters 31

13 References 33

1 Revisions

This document is the first version.

2 Introduction

This document is to be used by the Foundation Designer in connection with conceptual design for wind turbine foundations for Kriegers Flak. This Design Basis cannot be used for the Tender design.

Geotechnical reports etc. are later included as annexes.

The Site Assessment has been made as a separate report.

The Foundation Designer may choose to comply fully or partly with the Design Basis.

To the extent that full compliance with the Design Basis is deviated:

- Deviations shall be detailed stated
- Deviations shall be accepted by the Employer

The Design Basis applies for foundation concepts of:

- Concrete Gravity Base Structure (GBS),
- Steel monopile
- Jacket structure
- Concrete or steel tripod

Some of the specifications are only relevant for one of the foundation types this is indicated by the leading text of either GBS:, Monopile:, Jacket: or Tripod:. In certain cases common specifications for both jacket and tripod are given under the term Piled Structures:

The Design Basis includes a level of detail sufficient for the following:

- Conceptual design of foundation
- Conceptual design of appurtenances
- Specification of materials
- Specification of safety levels

The level of safety shall match the level presently achieved for land based wind farms. This shall be accomplished by using the codes specified in sub-clause 3.1. All demands, requirements and prerequisites shall be met when designing the foundations including any temporary structures and designs such as lifting points etc.



Figure 2.1 Map of the western Baltic Sea south of Sweden and the site: Kriegers Flak II

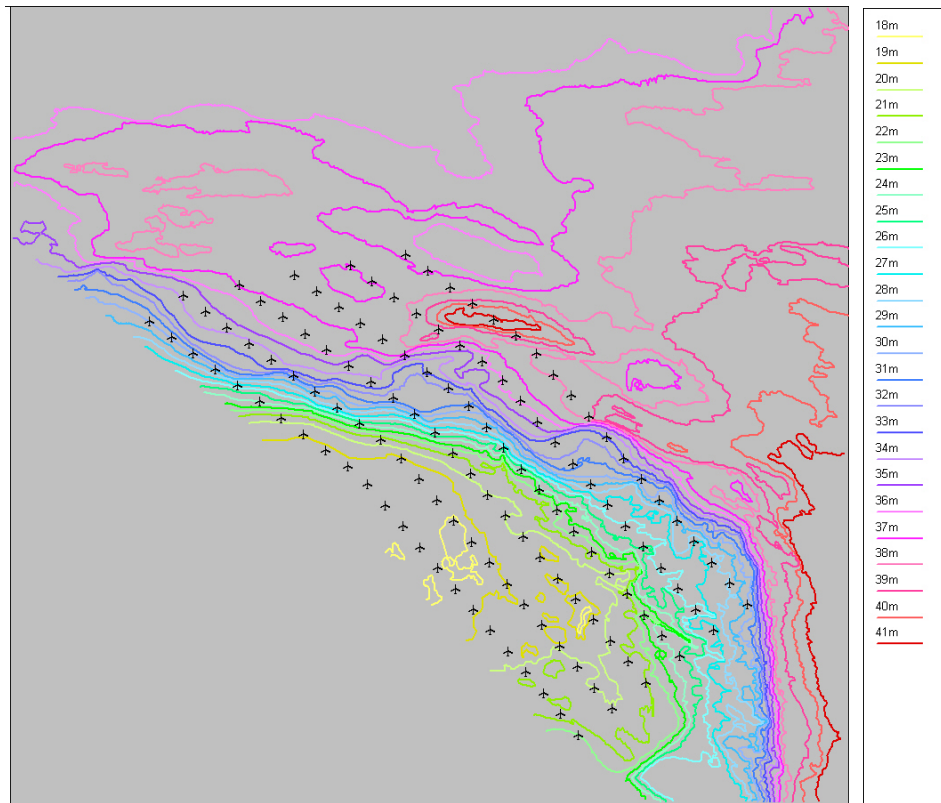

Figure 2.2 Location of the turbines.

3 Design principles

3.1 Codes and standards

The Design Basis is based on IEC 61400-3 and DNV-OS-J101 Design of Offshore Wind Turbine Structures/GL Guideline for certification of offshore wind turbines.

The overall hierarchy of the documents as given below and shall be governing for the design. Unless stated otherwise in the Design Basis all documents shall be used in the latest edition.

Regarding Steel structures

1. Design Basis for Foundations (this document).
2. IEC 61400-3: Design requirements for Offshore Wind Turbines.
3. DNV-OS-J101: “Design of Offshore Wind Turbine Structures”, 2007 or GL Guideline for certification of offshore wind turbines (latest version).
4. EuroCode no. 3: “Design of Steel structures”.

Regarding Concrete structures

1. Design Basis for Foundations (this document).
2. IEC 61400-3: Design requirements for Offshore Wind Turbines,
3. DNV-OS-J101: “Design of Offshore Wind Turbine Structures”, 2007 or GL Guideline for certification of offshore wind turbines (latest version).
4. DNV-OS-C502: “Offshore concrete Structures”, July 2004.
5. EuroCode no. 2: “Design of Concrete structures” 1992-1-1.

In case of conflict between the requirements, the above ranking shall be used.

3.2 General design conditions

The design of the foundations shall ensure a lifetime of 25 in every aspect without planned replacement. The choice of structure, materials, operation and inspection programme shall be made accordingly.

Fatigue loads are to be based on repetition over 25 years.

Climate loads such as wind, waves etc. shall be determined based on a recurrence period of 50 years.

The safety of the foundation design will be implemented according to the partial safety factor method.

4 Co-ordinate system

All reference shall be according to the co-ordinate system presented in the figure below. Origin (0,0,0) is located in the centre of the turbine tower at level +0.0 relative to Mean Sea Level (MSL). Minimum clearance from MSL Mean Sea Level to blade tip is 23 m. Interface between foundation and tower is found at level MSL +3.5 m.

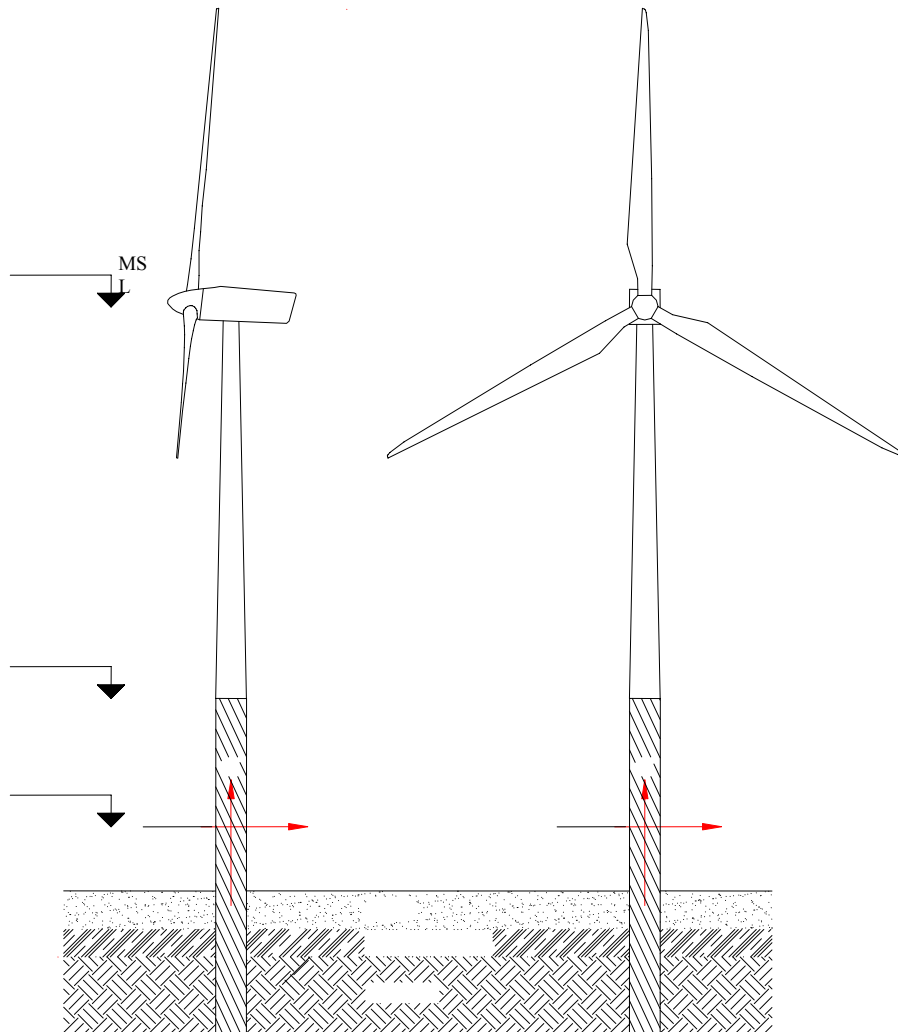

Figure 4.1 Reference co-ordinate system.

5 Wind Turbine

5.1 Wind Turbine layout

For the concept design two turbine sizes shall be investigated: 3.6 MW and 5 MW.

In Table 5.1 are presented the main parameters for the reference wind turbines and towers. The wind turbine is pitch and frequency regulated. Clearance to the blade tip at MSL is 23 m. Foundation loads in the Design Basis is based on the reference turbines.

Table 5.1 Reference turbines.

Turbine size	3.6 MW	5 MW
Output power	3.6 MW	5 MW
Rotor diameter	106 m	126 m
Foundation – tower interface level acc. MSL	3.5 m	3.5 m
Hub height above foundation interface	72.5 m	82.5 m
Nacelle mass incl. Rotor	220 tons	410 tons
Tower top diameter/wall thickness	3.5 m/15 mm	4.5 m/20 mm
Tower bottom diameter/wall thickness	4.5 m/30 mm	6.0 m/35 mm
Tower mass	220 tons	300 tons

6 Foundation dimensions and tower interface

6.1 GBS: Foundation – tower interface

The tender design shall be made for a double sided tower flange with dimensions of embedded parts, according to Table 6.1. Final dimension will depend upon the wind turbine tower.

Anchor bolts are covered with tar, crimp-able plastic or alike in order to reduce friction to the concrete, and improve the pre-stress conditions for the anchor bolts. Design of embedding and anchoring the bolts and anchor ring are the Foundation Designer responsibility. Both extreme, fatigue and pre-stressing loads shall be considered.

Table 6.1 Foundation groups and numbers in each group for GBS.

Turbine Size	3.6 MW	5 MW
Number of anchor bolts M42	2 × 80	2 × 120
Tower bottom outer diameter	4 500 mm	6 000 mm
Length of anchor bolts	1 500 mm	1 500 mm
Pre-stressing of bolts	350 MPa	350 MPa

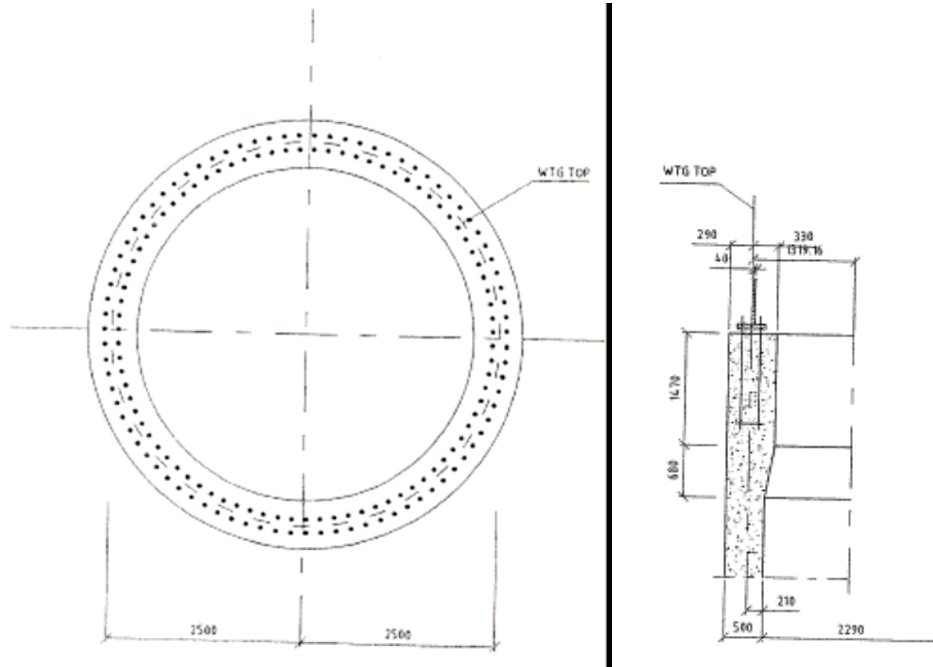

Figure 6.1 Sketch of double sided flange for GBS.

6.2 Monopile and jacket: Foundation – tower interface

The tender designed shall be made for a one sided flange with dimensions according to Table 6.2. Final dimension will depend upon the wind turbine.

Table 6.2 Foundation groups and numbers in each group for monopile and jacket.

Turbine size:	3.6 MW	5 MW
Number of bolts	100	160
Size of bolt holes DN	45 mm	45 mm
Tower bottom outer diameter	4 500 mm	6 000 mm

7 Combined Loads

Combined loads have been found according DNV-OS-J101 for load cases in four categories:

ULS Ultimate Limit State analyses

ALS Accidental Limit State analysis

SLS Serviceability Limit State Analyses including natural frequency analysis

FLS Fatigue Limit State Analysis including pile driveability

The above load cases have been investigated for the present structure. The result is summarized in two situations in the Design Basis:

- ULS loads
- FLS loads

GBS: Loads for calculation of crack width are found in sub-clause 8.7.

Load factors

Load factors according: IEC 61400-3 are used, as follows:

- Environmental ULS load: 1.35
- Environmental ULS load (abnormal wind load):1.10
- Environmental ALS load:1.10
- Environmental FLS load:1.00
- Gravity Load:1.00 (when conservative estimates are used)

The governing load for the foundation will be environmental load from wind, wave and currents.

The ULS load factor for waves may be reconsidered when the final foundation has been selected.

In the following design loads are specified – load factors are applied where applicable.

Foundation groups

To ease calculation of the foundation loads for all foundations in the wind farm the foundations are grouped in three groups according the water depth ref. MSL at their position, according to Table 7.1. Foundation loads will be specified for each group. The loads can be inter- and extrapolated.

Table 7.1 Foundation groups and numbers in each group.

	Water depth at MSL [m]	Numbers in the groups
Low	20	28
Medium	30	48
Deep	40	50

7.1 Turbine loads

Table 7.2 Turbine loads.

Turbine Design loads		Vertical load	Extreme loads		Operational loads		Fatigue loads m=(4-5) N:1×10 ⁷	
Tower bottom	Level [m]	[MN]	F_ex [MN]	M_ex [MNm]	F_op [MN]	M_op [MNm]	F_eq [MN]	M_eq [MNm]
KRF 3.6 MW	15	4.4	1.42	89.9	0.85	54.0	0.35	19.2
KRF 5.0 MW	15	7.1	2.03	150.0	1.20	90.0	0.49	28.1

Table 7.3 Special design loads at 15m acc. MSL.

Special design cases	Torsion correlated with M_ex	Torsion alone correlated to 0.7 M_ex	Crack and settling forces at tower bottom	
	T_ex [MNm]	T_alone [MNm]	F_cr [MN]	M_cr [MNm]
KRF 3.6 MW	5.6	13	0.7	42
KRF 5.0 MW	7.9	18	1.0	70

The crack loads are found according the DNV-OS-J101 standard.

7.2 GBS: Loads

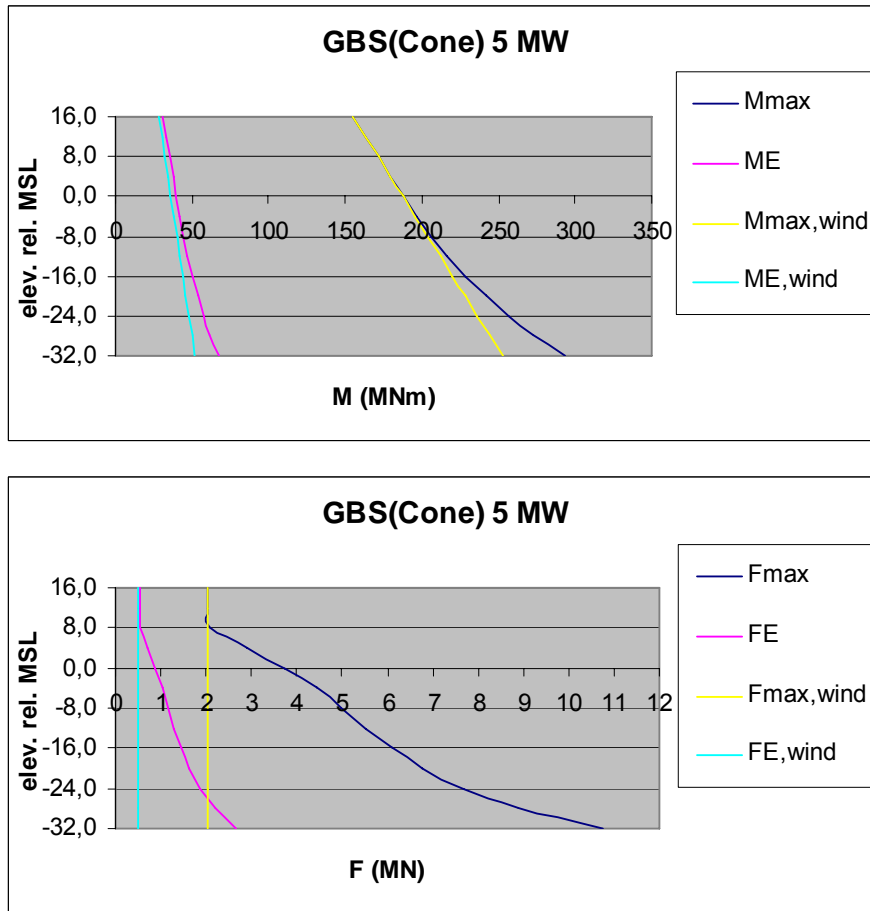

Figure 7.1 GBS: Levels and schematic vertical load distribution.

Table 7.4 GBS: Loads.

GBS Design loads		Extreme loads*		Operational loads		Fatigue loads m=(4-5) N:1×10 ⁷	
Sea bed	Depth [MN]	F_ex [MN]	M_ex [MNm]	F_op [MN]	M_op [MNm]	F_eq [MN]	M_eq [MNm]
KRF 3.6 MW	-20	6.4	161	5.6	114	1.6	40
KRF 3.6 MW	-32	10.4	214	7.2	136	2.7	53
KRF 5.0 MW	-20	6.8	241	6.5	165	1.6	54
KRF 5.0 MW	-32	10.8	293	10.3	204	2.7	67

*Add torsion as specified in Table 7.3

7.3 Mono-pile: Loads

The load graphs are extended so they include wind plus wave forces below sea bed, but not soil forces.

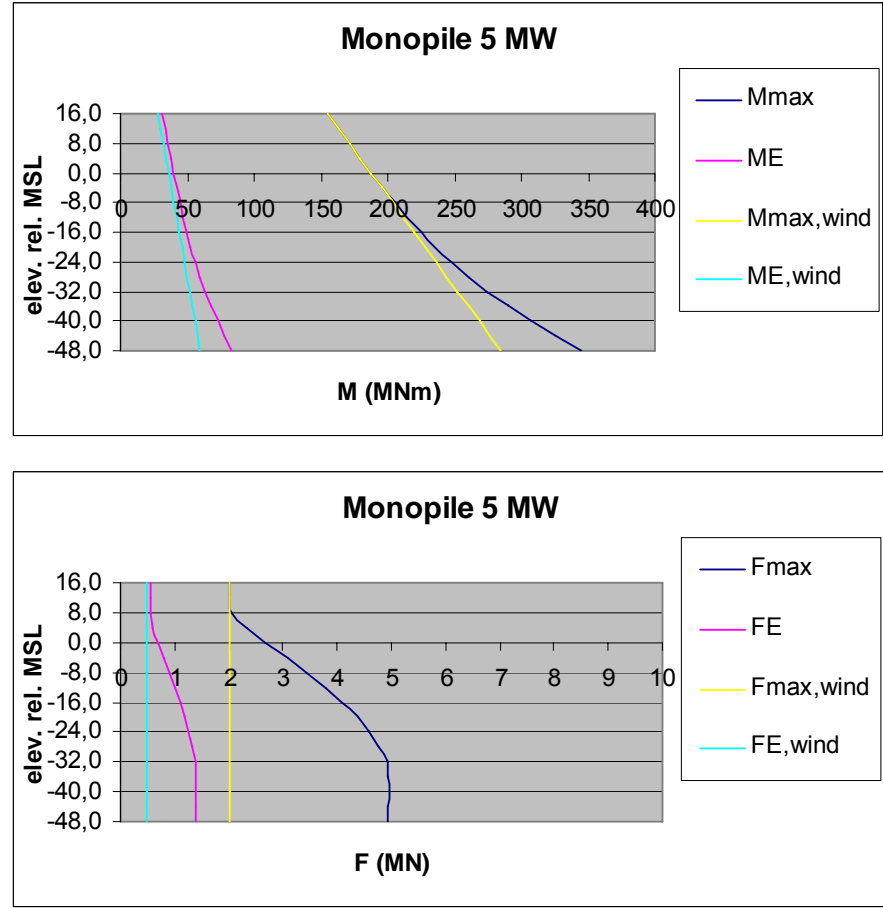

Figure 7.2 Mono-pile: Levels and schematic vertical load distribution.

Table 7.5 Monopile: Loads.

Mono-pile Design loads		Extreme loads*		Operational loads		Fatigue loads m=(4-5) N:1×10 ⁷	
Sea bed	Depth [m]	F_ex [MN]	M_ex [MNm]	F_op [MN]	M_op [MNm]	F_eq [MN]	M_eq [MNm]
KRF 3.6 MW	-20	4.0	153	2.7	104	1.2	41
KRF 3.6 MW	-32	4.6	191	3.4	122	1.3	49
KRF 5.0 MW	-20	4.4	236	3.5	154	1.2	53
KRF 5.0 MW	-32	4.9	275	4.9	185	1.4	64

*Add torsion as specified in Table 7.3

7.4 Jacket: Loads

The load graphs are extended so they include wind plus wave forces below sea bed, but not soil forces.

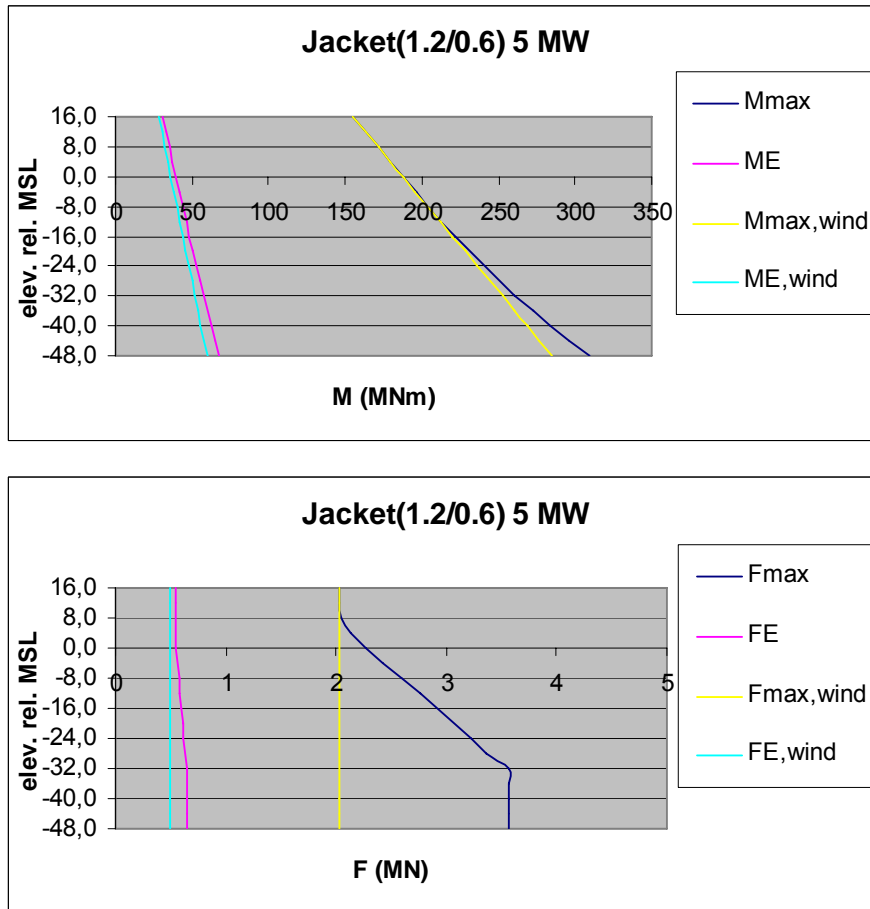

Figure 7.3: Jacket: Levels and schematic vertical load distribution.

Table 7.6 Jacket: Loads.

Jacket-pile Design loads		Extreme loads*		Operational loads		Fatigue loads m=(4-5) N:1×10 ⁷	
Sea bed	Depth [m]	F_ex [MN]	M_ex [MNm]	F_op [MN]	M_op [MNm]	F_eq [MN]	M_eq [MNm]
KRF 3.6 MW	-20	2.7	146	1.9	93	0.5	35
KRF 3.6 MW	-32	3.2	170	2.3	106	0.5	40
KRF 5.0 MW	-20	3.1	231	2.5	142	0.6	53
KRF 5.0 MW	-32	3.6	260	3.3	162	0.7	58

*Add torsion as specified in Table 7.3

7.5 Ship impact loads

The foundation and boat landing arrangement will be dimensioned for ship impact from service vessels and alike.

7.5.1 Ship impact ALS (*Accidental Limit State*)

The foundations shall be able to withstand impact from vessels with a shock energy of 500 kJ and a static equivalent force of 4.9 MN at the boat landing area between level MSL and level MSL +5 m (acc. the design) corresponding to a vessel with a displacement of approximately 160 ton hitting a soft fender with a maximum deformation of 0.2 m with a velocity of 2.0 m/s hitting broadside or from bow/stern direction. The load area is assumed to be: $A = 0.2 \text{ m} \times 0.2 \text{ m}$.

7.5.2 Ship Impact ULS (*Ultimate Limit State*)

The lower part of the boat landing shall be designed to withstand bow impact from vessels with a shock energy of 30 kJ and a static equivalent force of 300 kN between level MSL and level MSL +5 m (acc. the design) corresponding to a vessel with a displacement of approximately 160 ton hitting a soft fender with a maximum deformation of 0.2 m with a velocity of 0.5 m/s hitting broadside or from bow/stern direction. The load area is assumed to be: $A = 0.1 \text{ m} \times 0.1 \text{ m}$.

8 Other design criteria

8.1 Natural frequency

The stiffness of the foundation shall be sufficient to give a first natural frequency for the whole wind turbine structure and foundation including soil stiffness if the following range:

Allowable frequency range:

For 3.6 MW: 0.31 Hz to 0.34 Hz

For 5.0 MW: 0.26 Hz to 0.29 Hz

The properties to be used for the turbine structure are found in sub-clause 5.1. Linear distribution of the tower diameter and material thickness shall be used.

8.2 Allowed settlement

GBS: Maximum allowable settlement of the GBS foundation is 0.50°.

Monopile: Maximum allowable tilt of the mono-pile foundation is 0.25°.

8.3 Corrosion

Corrosion allowance shall be included in the design.

8.4 Material coefficient

According to EuroCode no. 2: “Design of concrete structures”, 1992-1-1 the safety factor materials are according to Table 8.1.

Table 8.1 Material safety factors for concrete structures.

	ULS	FLS and ALS	SLS
Concrete	1.50	1.50	1.00
Reinforcement	1.15	1.15	1.00

8.5 Stiffness parameters

The elasticity modulus is as the initial elasticity modulus according EuroCode 2.

The elasticity modulus is used without safety factor.

The foundation stiffness shall be calculated for the cracked structure.

8.6 Pre stressing of anchor bolts.

Loads from pre-stressing of the anchor bolts acc. sub-clause 6.1 shall be taken into account.

8.7 Crack width

Crack width shall not exceed the figures in Table 8.2.

Crack width shall be calculated according to DNV-OS-J101 for operational loads as stated in sub-clause 7.1.

The Elasticity modulus of the concrete shall be found according to DNV-OS-J101.

The load for the first crack is found using the lower characteristic tensile strength (EuroCode 2 clause 3.1.2.3).

Table 8.2 Allowable crack width.

Level acc. LAT [m]	Crack width [mm]
Above 11	0.2
11 – (-4.0)	0.1
(-4.0 – (-15.0))	0.2
Below level (-15)	0.3

8.8 Fatigue

The fatigue life shall be calculated according to Palmgren-Miner cumulative damage law. The allowable damage ratios are presented in Table 8.3.

Table 8.3 Allowable Palmgren-Miner damage sum.

Level acc. LAT [m]	PM sum
Above 11	1.0
11 – 0	0.5
Below 0	0.3

The use of Wöhler-curves shall be in accordance with the safety system for which they are valid. If Wöhler curves from DNV-OS-J101 / DNV-OS-C502 are used, the material parameter 1.15 shall be used.

9 Secondary constructions

9.1 Loads – boat landing

Loads from vessels should be according sub-clause 7.5.

9.2 Loads – wave loads to appurtenances

Design should include appropriate account to slamming forces and include both extreme loads and fatigue loads.

9.2.1 Run-up

The max run-up heights is estimated to $R_{\max} = +13.7$ m (rel MSL) (see Site Assessment).

9.2.2 Vertical velocity for vertical structures

The vertical design velocity in a certain elevation h may be determined from:

$$U = (2 g (R_{\max} - h))^{0.5}$$

where g = gravitational acceleration

9.2.3 Horizontal velocity for vertical structures

The flow around a cylinder derived from potential flow theory is sketched on Figure 9.1. The maximum flow velocity around the cylinder is twice the free-stream velocity. The real case is not exactly a potential flow and are governed by the particle velocity generated by the waves and the boat landing are not placed at the monopile surface, but never the less the maximum load on the boat landing elements are calculated based on a estimated velocity of two times the velocity found with no monopile structure involved ($u_{\max} = U_{\infty} = 6.0$ m/s).

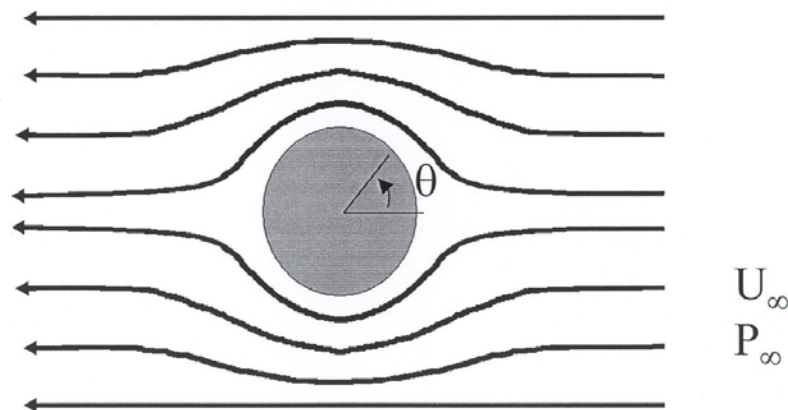

$$U(\theta) = 2 \cdot U_{\infty} \cdot \sin(\theta)$$

(P_{∞} = pressure without influence of structure)

Figure 9.1 Potential flow velocity around a cylinder/monopile.

9.3 Extreme horizontal wave loads.

Forces on the main structure are calculated on basis of Stream function calculations.

Stream function theory describes velocity field for $U = U_{\max}$ (< 6.0 m/s).

Account to distance from main cylinder on horizontal velocities is estimated as follows relative to a distance x from the cylinder with diameter D :

$$U/U_{\max} = (2x/D)^2 - 2(2x/D) + 2 \text{ for } x < D/2$$

$$U/U_{\max} = 1 \text{ for } x \geq D/2$$

The estimate above is valid for structures placed 90° relative to the incident wave direction, where the structure amplifies the wave velocity most (up to a 2 factor).

A conservative design could be to apply an extreme basis velocity (maximum wave + current) of 6 m/s from 0 m above MSL to +6.0 m above MSL and 4 m/s below MSL.

Forces on the Appurtenances are calculated (as drag forces) on basis following formulae (The form factor is equal to 1):

$$F = 0.5 \rho U^2 A$$

If we consider a 0.4 m pipe section with a length of 1.5 m ($A = 0.6 \text{ m}^2$) exposed to a maximum velocity of $2 \times 6 \text{ m/s} = 12 \text{ m/s}$. The extreme load from the waves is estimated to

$$F = 0.5 \rho U^2 A = 0.5 \times 1010 \times 12^2 \times 0.6 = 44 \text{ kN.}$$

9.4 Slamming force (vertical)

The extreme vertical **design** forces (slamming force) from the waves are estimated as follows:

The vertical maximum velocity is calculated from:

1. R_{\max} = Maximum run-up (1/50 years) (above MSL).
2. A structure in elevation h (above MSL) is considered.
3. The maximum vertical velocity is estimated from:
 - $U_{\text{wave,vert.}} = (2 g (R_{\max} - h))^{0.5}$, g = acceleration of gravity = 9.81 m/s^2 .
4. Slamming force $F_{\text{sl}} = 0.5 \rho C_s A U_{\text{wave,vert.}}^2$ where ρ = water density, C_s = slamming coefficient and A = area considered.
5. Slamming coefficients:
 - Cylindrical structures: $C_s = \text{minimum } 3$.
 - Triangular and rectangular structures: $C_s = \text{minimum } 6$.
 - Horizontal platform: $C_s = 10$ for a load area of 0.5 m^2 and $C_s = 1.5$ for the average load.

- Cone platform: $C_s = 6$ for a load area of 0.5 m^2 and $C_s = 1.2$ for the average load.

9.5 Fatigue loads

Procedure for fatigue loads to appurtenances:

To be included later in conceptual design if appropriate.

10 Geotechnical Design

10.1 General

The geotechnical design shall be performed in accordance with DNV-OS-J101 ref. [1] or GL Guidelines ref. [10].

It is the task and the responsibility of the Contractor to analyse and interpret all available geotechnical information and reports from surveys, site investigations, laboratory testing etc. as included as annexes.

In order to ease the tender process, an interpretation has been carried out by the Employer and summarized in the Site Assessment and the following clauses.

10.2 ULS Analyses

The partial coefficients for soil parameters and resistance parameters shall be:

ULS Plastic

- Angle of Internal Friction 1.2
- Undrained Shear Strength 1.3
- Pile Axial Bearing Capacity 1.3

10.3 SLS Analysis, ALS Analysis and FLS Analysis

Characteristic soil parameters shall be used in the ALS, SLS analysis, natural frequency analysis, fatigue analyses and the pile driveability study. The partial coefficients shall be taken as unity.

10.4 Undrained Shear Strength Parameters from Cone Tip Resistance

The in situ measured cone penetration tests shall be compared with the undrained tri-axial tests from the borings in order to determine the relationship between the cone resistance and the undrained shear strength, i.e. the N_k value. This relationship, expressed by the N_k value, has then been used to determine undrained shear strengths from the CPT tests in clays.

The undrained shear strength, c_u can be expressed by the following formula:

$$c_u = \frac{q_c - \sigma}{N_k}$$

where q_c is the net cone tip resistance
 σ is the total overburden pressure
 N_k is the cone factor

10.5 Friction Angle from the Cone Tip Resistance

The interpretation of the angle of internal friction in sand can be carried out by the method described in ref. [7]. Here a relationship between the peak secant friction angle and the relative density for different grain-size characteristics is given. The friction angle shown in Figure 10.1 appears to an effective overburden stress of

150 kPa. If the overburden stress is higher than 150 kPa and less than 300 kPa, the friction angle shall be reduced by 1 degree.

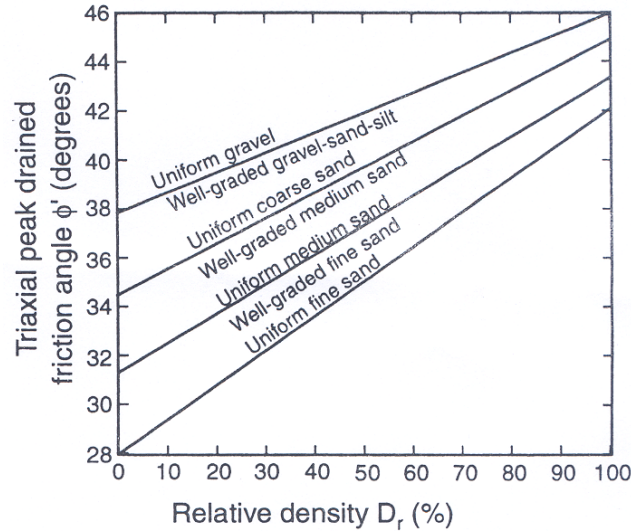

Figure 10.1 Relationship between the friction angle and the relative density, ref. [7].

Baldi et al. 1986 ref. [5] recommended the following formula to estimate the relative density of normally and over consolidated sands based on the cone tip resistance:

$$D_r = \frac{1}{2.61} \ln \left[\frac{q_c}{181 \cdot (\sigma'_m)^{0.55}} \right]$$

where D_r is the relative density
 q_c is the cone tip resistance
 σ'_m is the effective vertical stress

The correlations based on the above formula and the soil constants are shown in Figure 10.2.

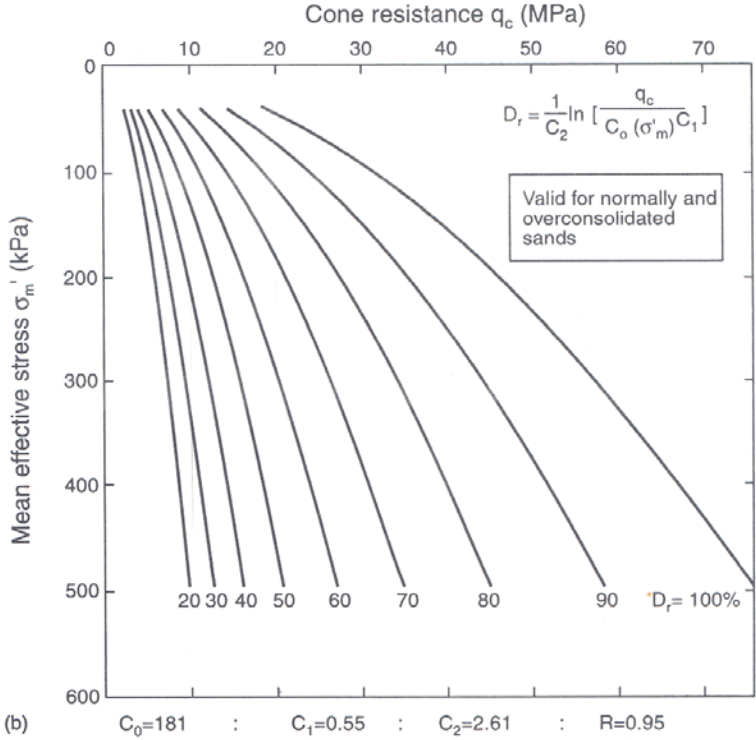

Figure 10.2 Relationship between cone tip resistance, vertical stresses and relative density, ref. [5].

These two relationships can be combined to a relationship between the angle of internal friction and the cone tip resistance. The relation is depicted in Figure 10.3 for fine sand.

Schmertmann, 1978 and Baldi et al. 1986

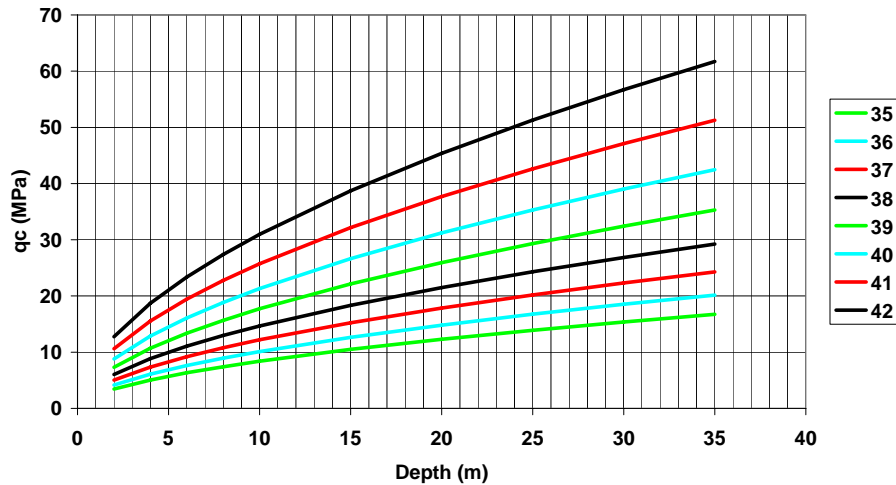

Figure 10.3 Evaluation of Angle of Internal Friction in Fine Uniform Sand.

The correlation given in Figure 10.3 shall be used to interpret the angle of internal friction for the sand deposits. The friction angle will be limited to 42°.

This approach appears rational and conservative. The curves are implemented on all the CPT's.

10.6 Preliminary proposal for geotechnical design profiles

The soil investigations have not been finalized complete. Final interpretation of field test, coordination with geophysical investigation plus some of the more detailed laboratory tests has not been finalized.

On the basis of a relatively rough analysis the following preliminary estimate of simplified design soil profiles has been made in the Site Assessment (subject to revision when further data are available):

Table 10.1 Preliminary proposal for simplified design geotechnical profiles.

	c_u or φ	c_u or φ	c_u or φ	c_u or φ	Lime stone
	0-1m below seabed	1-4 below seabed	5-7 below seabed	8-50 below seabed	[50; ∞]
Profile 1, sand	50 kPa	37°	42°	300kPa	H2
Profile 2 Clay	50 kPa	200 kPa	400 kPa	300 kPa	H2
Profile 3 Soft	50 kPa	35°	50 kPa	400 kPa	H2

NOTE

- In depths (rel. MSL) below -27 m deposits of clay till with $c_u = 600-1,200$ kPa may be present.
- Limestone with an induration-degree of H3 may be present and with a thickness of app. 2 m.
- Gravels are found in most of the clay below -27 m. A single bore profile specifies stone at the end of the profile. Otherwise is noted risk of cobbles and boulders. The risk for larger boulders is estimated to be of an order of 2 to 4 % per position.
- Silt/peat may occur in a few sites with a layer thickness of max 1 m.

The limestone is characterized in the classes presented in Table 10.2, with associated strength and deformation parameters (σ_c = laboratory value of uniaxial compression strength, E = modulus of elasticity, σ_t = tensile strength and $I_{s(50)}$ = point load strength index).

Table 10.2 Reference frames for characteristic limestone element strength and deformation parameters correlated to rock grade.

ISRM Rock Grade	DGF Degree of induration	σ_c MN/m ²	E MN/m ²	σ_t MN/m	$I_{s(50)}$ MN/m
R0	H1	0.25–1	100–1 000	n.a.	n.a.
R1	H2	1–5	1 000–5 000	0.2–1	0.1–1
R2	H3	5–25	5 000–25 000	1–4	1–4
R3 + R4	H4	25–100	25 000–100 000	4–10	2–8
R5 + R6	H5	100–500	100 000–500 000	10–50	4–20

Note: n.a.: Not applicable

10.7 Dynamic Soil Spring Stiffness

The initial, small strain modulus is denoted G_o . In Figure 10.4 the G_o/q_c is depicted for uncemented quartz sand.

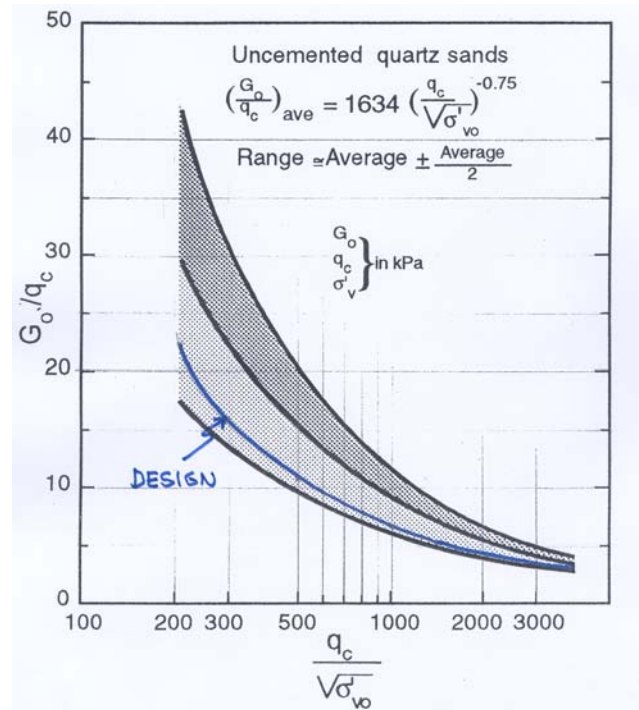

Figure 10.4 G_{max}/q_c , ref. [6].

The design value can be taken as:

$$\frac{G_o}{q_c} = 1200 \cdot \left[\frac{q_c}{\sqrt{\sigma'}} \right]^{-0.75}$$

where G_o is the small strain shear modulus
 q_c is the cone tip resistance
 σ' is the effective vertical stress

Valid for $\varepsilon \leq 10^{-3} \%$

For clay deposits the initial small strain modulus can be taken as:

$$G_o = 1000 \cdot c_u \text{ for } \varepsilon < 10^{-3} \%$$

where c_u is the undrained shear strength.

10.8 Risk of Liquefaction due to Cyclic Loading

The cyclic liquefaction resistance shall be evaluated for silty fine sand with low relative density.

The possibility of wind and wave producing liquefaction in the foundation sands is similar in some respects to the problem of earthquake-induced liquefaction. Both cases involve cyclic shear stresses induced on horizontal planes. Further details: See Lee et al Ref. [6].

The NAVFAQ DM-7.3 approach can as an initial evaluation method be used.

For monopile foundation the loose silty sand will liquefy for lateral loading. In design of monopile the soil deposits above the bottom of the loose silty sand shall be ignored. Bottom of the loose silty sand deposits at the actual turbine locations are indicated in the Site Assessment.

11 Monopile: Geotechnical Parameters

11.1 Soil-Structure Interaction

Generally, the following effects regarding soil and soil-structure interaction shall be taken into account in the entire analyses:

- Non-linear behaviour of the interaction between soil and monopile, laterally and axially.
- The length of the soil plug inside the monopile is taken as 0.9 times the length of the pile embedded in the soil due to compaction of the soil during pile driving.

11.2 Soil Curves

11.2.1 Axial Bearing Capacity, t-z and Q-W Curves

The unit skin friction and the tip resistance shall be calculated in accordance with the DNV-approach using the characteristic soil parameters.

Cyclic t-z curves in accordance with DNV shall be used. Ref. [1] DNV:

The tip load-displacement curves, Q-W shall be taken as Ref. [4] API:

Table 11.1 Tip load displacement.

W/D	Q/Q _p
0.002	0.25
0.013	0.50
0.042	0.75
0.073	0.90
0.1	1.00

Where W is axial tip deflection (mm)

D is pile diameter (mm)

Q is mobilized end bearing capacity (kN)

Q_p is total end bearing capacity (kN)

11.2.2 Lateral Bearing Capacity, ULS Elastic Analyses, p-y Curves

The lateral bearing capacity shall be based on p-y data developed by the DNV-approach.

For clay the first point on multi-linearly curves shall be taken as $y/y_c = 0.1$ and $p/p_u = 0.23$ in order to get a better model for small strain behaviour. The approach is in line with the ISO approaches, ref. [3] as shown on Figure 11.1

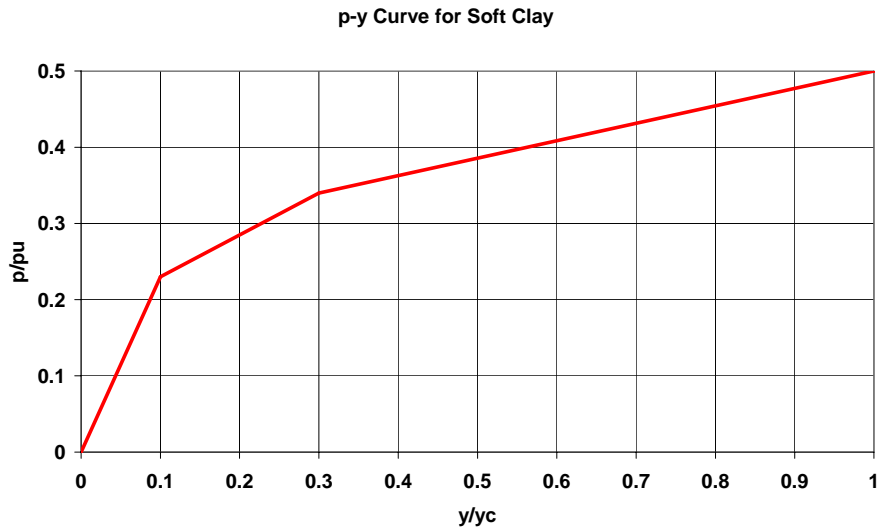

Figure 11.1 *p-y curves for clay, ref [3].*

y_c is calculated as:

$$y_c = 2.5 \cdot \varepsilon_{50} \cdot D$$

ε_{50} is strain which occurs at one-half the maximum stress on laboratory undrained compression tests. D is the pile diameter.

The ε_{50} value for clay can be taken according to Table 11.2.

Table 11.2 *Representative values for ε_{50} for unified criteria, ref. [8].*

c_u [kPa]	ε_{50}
12–25	0.02
25–50	0.01
50–100	0.007
100–200	0.005
200–400	0.004

The $p-y$ curves specified for cyclic loading conditions shall be applied for representation of the lateral support.

11.2.3 Lateral and Axial Bearing, Fatigue Analysis, Spring Constant

The lateral and axial bearing capacity in the fatigue analysis shall be modelled as spring constants.

The soil pile interaction relationship is normally a smooth curve. The spring constants used in the linear analysis shall be taken as the initial slope of the smooth curve.

11.3 Minimum Wall Thickness

For piles that are to be installed by driving and hard driving (200 blows per 0.25 m) is anticipated, the minimum wall thickness used should not be less than, ref. [4] API:

$$t = 6.35 + \frac{D}{100}$$

where t is the wall thickness of the pile

D is the outside diameter of the pile

11.4 FLS – Driveability and Fatigue Analysis

The driveability studies and driving fatigue analyses shall be carried out for the piles. Upper bound of the cone tip resistances shall be used.

The driveability and fatigue study shall be performed to investigate if the piles can be driven safely to the target penetration and to ensure that the fatigue damage, which can occur during driving is acceptable.

11.4.1 Driveability Study

The driveability study shall be performed using a dynamic analysis, which is fully capable of representing the stress wave propagation (inclusive reflection) through the pile. All sections in the pile shall be modelled. The analysis shall include a detailed model of the hammer based on hammer specific information.

11.4.2 Pile Driving Fatigue

The installation induced partial fatigue damage shall be calculated by applying the following procedure:

Each pile is divided into a number of elements during the driveability analysis in order to specify maximum and minimum stress for each element at each depth analysed and for each stroke. The stress range is calculated from these stresses.

The accumulated damage for each element is calculated by adding the damages down to the actual driving depth.

12 GBS: Geotechnical Parameters

12.1 Vertical Bearing Capacity

The vertical bearing capacity analysis shall be carried out for the extreme design loading and ULS condition in accordance with DNV approach, ref. [1] or GL approach, ref. [10].

12.2 Sliding

Horizontal forces to be used for check of sliding failure shall be determined taking into account the combined action of horizontal force and torsional moment. The method is described in DNV.

The sliding resistance of the gravity base shall be determined according to DNV rules assuming that the strength parameters for intact soil apply.

In case of foundations are excavated into cohesive soils the weakening of the thin upper zone shall be taken into consideration.

12.3 Skirt Penetration Analyses

The skirt penetration resistance shall be calculated based on cone tip resistance in accordance with DNV.

12.4 Soil Reactions

Installation load case and permanent load case shall be analysed.

12.4.1 Installation load case

For the installation case the load case cover the period from first seabed contact until the under-base grouting operation has been completed and the grout has cured.

12.4.2 Permanent load case

During the extreme event it is expected that the vertical loads on the skirts will tend to go over to the base. If settlement takes place after the extreme event the loads will tend to go back from the base to the skirts. Therefore the following two assumptions shall be used for the analysis of the foundation base:

1. All permanent loads are carried as a uniform vertical stress against the grout.
2. The skirts carry all the permanent vertical loads as skin friction.

12.4.3 ULS load case.

The soil reaction on the contact face of the base slab shall be assumed to be distributed according to the one assumption, out of the two described below, which gives the most severe loading on the base slab.

- Uniform distribution over an effective foundation area.
- Re-distribution contact pressure, calculated according to the theory of elasticity.

12.5 Settlements

For SLS design conditions, analyses of settlements and displacements shall be investigated in accordance with DNV/GL.

13 References

1. DNV Offshore Standard: DNV-OS-J101 “Design of Offshore Wind Turbine Structures”, 2007.
2. DNV Offshore Standard: DNV-OS-C502 “Offshore Concrete Structures”.
3. ISO/CD 19902 Fixed Steel Offshore Structures 2001.
4. American Petroleum Institute API (2000). API Recommended Practice for Planning, Designing and Construction Fixed Offshore Platforms – Working stress Design API-RP2A-WSD, 21st edition, December 2000.
5. Baldim, G., Bellotti, R., Ghionna, V., Jamiolkowski, M. and Pasqualini, E. (1986). Interpretation of CPTs and CPTUs; 2nd part: drained penetration of sands. Proceedings of the Fourth International Geotechnical Seminar, Singapore, 143-156.
6. Lee, L. Kenneth, Facht, A. John. Liquefaction Potential at Ekofisk Tank in North Sea. ASCE January 1975.
7. Schmertmann, J. H. (1978) Guidelines for Cone Penetration Test; Performance and Design. U.S. Department of Transportation. Federal Highway Administration, Wash. D.C. FWHA-TS-78-209.
8. Sullivan, W.R., Reese, L. C. & Fenske, C. W. “Unified Method for Analysis of laterally loaded piles in clay” Institution of Civil Engineers. Numerical methods in offshore piling, London 1980, p. 135-146.
9. IEC 61.400-3: Ed.1 Wind turbines. Part 3. Design requirements for offshore turbines (CDV of august 2007).
10. GL (2004): Guideline for certification of offshore wind turbines.